

XY S653-A 3軸/3-axis

▶ 螺桿驅動
Ball Screw Drive

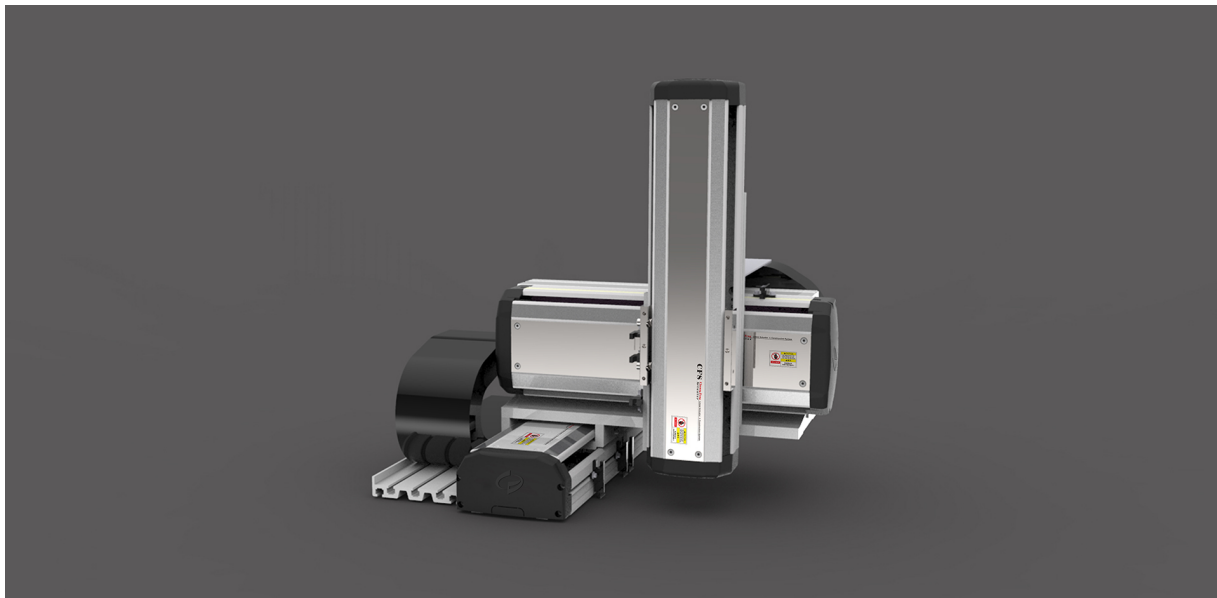

此圖僅供參考，出貨規格詳見尺寸圖面。
The picture is just for the reference. Please check the actual dimensions on the drawing.

※標準連結滑台不提供同動精度
Assembly accuracy is not guaranteed for the standard multi-axis system.

最大行程 Maximum Stroke

X軸 X axis 1050mm Y軸 Y axis 650mm Z軸 Z axis 350mm

最高速度 Maximum Speed

X軸 X axis 1000mm/s Y軸 Y axis 1000mm/s Z軸 Z axis 500mm/s

AC伺服馬達容量 AC Servo Motor Output

X軸 X axis 400W Y軸 Y axis 200W Z軸 Z axis 100W+煞車

基本仕様 Specification

項目 Item	X軸 X axis	Y軸 Y axis	Z軸 Z axis
軸型式 Model Type	CFS14	CFS13	CFS10
位置重複精度 Repeatability (mm)	±0.01	±0.01	±0.01
螺桿導程 Ball Screw Lead (mm)	20	20	10
最高速度 Maximum Speed (mm/s) *3	1000	1000	500
標準行程(50間隔) Stroke 50 mm Pitch (mm)	100~1050	50~650	50~350
AC伺服馬達容量 AC Servo Motor Output (w)	400	200	100+煞車
使用環境 Environment	0~40°C, 85%RH Below		

*3: 最高速度(mm/s)是以伺服馬達最高轉速3000rpm/min為基準。
Maximum speed is based on the AC servo motor's 3000RPM.

最大可搬重量 Maximum Payload

		Z軸荷重 Z Payload (kg)					
		Y軸行程 Y Stroke (mm)					
Z軸行程 Z Stroke (mm)	Y軸行程 Y Stroke (mm)	150	250	350	450	550	650
150	150	10	9	7	5	3	1
250	150	10	8	6	4	2	-
350	150	9	7	5	3	1	-

※限定水平安裝。
Only for horizontal installation.

型號表示方式 Ordering Method

XY S653 - A 1 - 600 - 450 - 200 - T - C - 0001

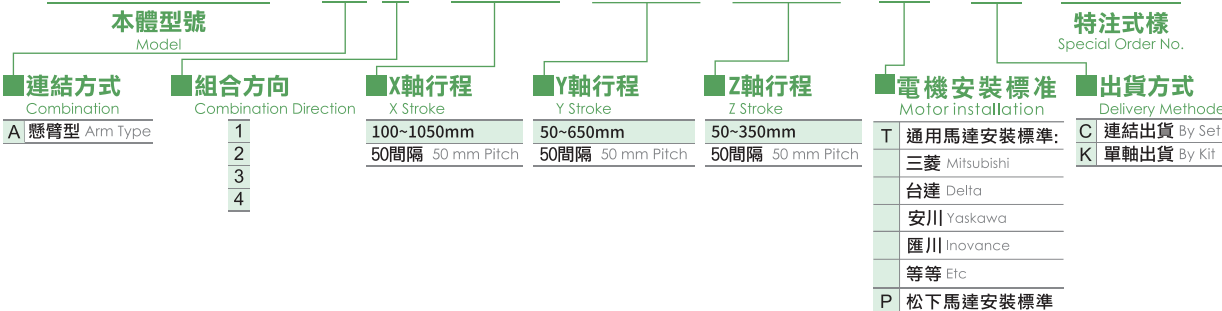

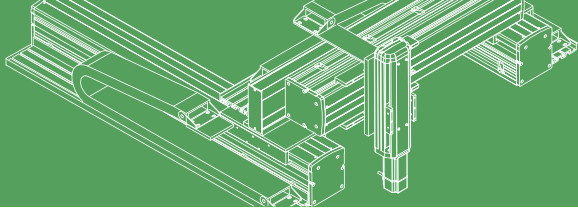

免費服務專線：大陸 400-716-8787
Toll-free Number China

XYSG653-A1 尺寸圖 Size

A1



• CAD圖面可至 www.cf16.com 下載 •

單位 Unit: mm

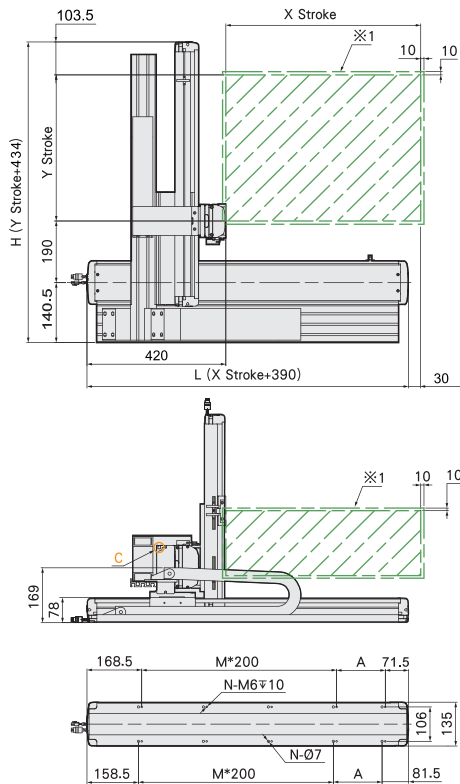

C-Cutaway View

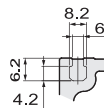

XY-Cable Chain

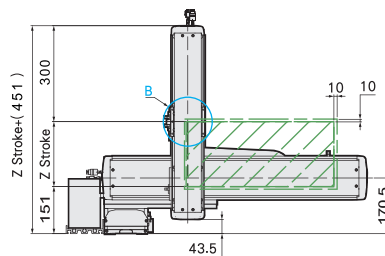
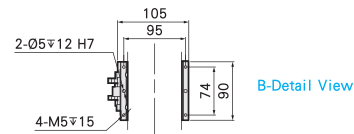
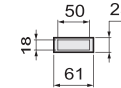

※1: 原點回復時的移動範圍及機械極限的停止位置。
The moving range of returning origin, the stop position of mechanical limit.

X軸行程 X Stroke (mm)	100	150	200	250	300	350	400	450	500	550	600	650	700	750	800	850	900	950	1000	1050	
L	490	540	590	640	690	740	790	840	890	940	990	1040	1090	1140	1190	1240	1290	1340	1390	1440	
A	50	100	150	200	50	100	150	200	50	100	150	200	50	100	150	200	50	100	150	200	
M	1	1	1	1	2	2	2	2	3	3	3	3	4	4	4	4	5	5	5	5	
N	6	6	6	6	8	8	8	8	10	10	10	10	12	12	12	12	14	14	14	14	
最高使用速度 Maximum Speed (mm/s)※4	1000															900	800	700	600	500	400

Y軸行程 Y Stroke (mm)	50	100	150	200	250	300	350	400	450	500	550	600	650
H	484	534	584	634	684	734	784	834	884	934	984	1034	1084
最高使用速度 Maximum Speed (mm/s)※4	1000												

※4: 最高使用速度代表該行程內可使用的最高安全速度，若超過此速度，滑台可能會有嚴重共振產生。
Maximum speed is refers to the highest safe speed that can be used in stroke, if more than the standard speed, table may produce serious resonance.

連結方向 Combination Direction

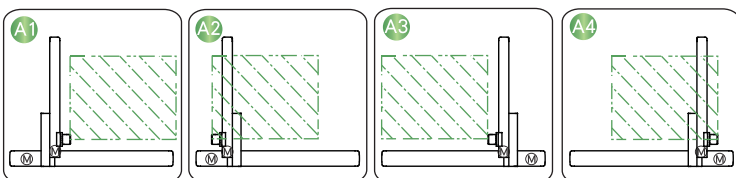

配件規格 Spec. Details

X軸詳細規格 X-axis Detail Spec.	→P315	Y軸詳細規格 Y-axis Detail Spec.	→P297
Z軸詳細規格 Z-axis Detail Spec.	→P269	馬達廠牌選定 Motor Brand Options	→P641

應用例

一般/內嵌式樣
CFG/CFV

無塵/皮帶式樣
CFA/CFB

一般/螺桿式樣
CFK

齒輪齒條式樣
CFM

一般/螺桿式樣
CFS

一般/皮帶式樣
CFT

無塵/螺桿式樣
CFF

無塵/皮帶式樣
CFE

直交連結
XYG/XYS/XVT

參考資料
Reference

XYSG
系列

XYSG-A

XYSG-G

XYSG-P

XYSG-F