

CFS27 1500W伺服電機

單軸/1-axis

▶ 螺桿驅動
Ball Screw Drive



此圖僅供參考，出貨規格詳見尺寸圖面
The picture is just for the reference. Please check the the actual dimensions on the drawing.

最大行程 Maximum Stroke	1950mm	最高速度 Maximum Speed	1066mm/s	馬達容量 Motor Output	1500W	滾珠螺桿 Ball Screw	Ø32mm	直線滑軌 Linear Guide	25X20-23
-------------------------------	---------------	------------------------------	-----------------	-----------------------------	--------------	---------------------------	--------------	-----------------------------	-----------------

型號表示方式 Ordering Method

CFS27 - L10 - 100 - BC - T1500W - C 4 - MB-3M

本體型號 Model	螺桿導程 Ball Screw Lead	行程 Stroke	馬達位置 Motor Position	電機安裝標準 Motor installation	馬達容量 Motor Output	原點感應器 Home Sensor	端點極限感應器 Limit Sensor	馬達廠牌 Motor Brand
	10 10mm 20 20mm 32 32mm	50-1950mm 50間隔 50 mm Pitch	BC 馬達外露 Motor Exposed BL 馬達左折 Motor Left Side BR 馬達右折 Motor Right Side BM 馬達下折 Motor Bottom Side	T/P 通用馬達安裝標準: 松下 Panasonic 台達 Delta 安川 Yaskawa M 三菱馬達安裝標準	100W - 200W - 400W - 750W - 1500W 1500W	內置型 In Side A 馬達側 Motor Side B 反馬達側 Opposite Motor Side 外掛型 Out Side C 馬達側 Motor Side D 反馬達側 Opposite Motor Side 無 SENSOR No Sensor E 無 SENSOR No Sensor	內置型 In Side 1 1只 1 Pc 2 2只 2 Pc 外掛型 Out Side 3 1只 1 Pc 4 2只 2 Pc 無 SENSOR No Sensor 5 無 SENSOR No Sensor	MB-3M 含電機，廠家安裝三菱帶利車電機，線長3米 ZMB 不含電機，客戶自己安裝三菱帶利車電機 KMB 不含電機，客戶提供三菱帶利車電機，廠家安裝

※若無煞車則B不表示。
※If No Brake, No B Description.

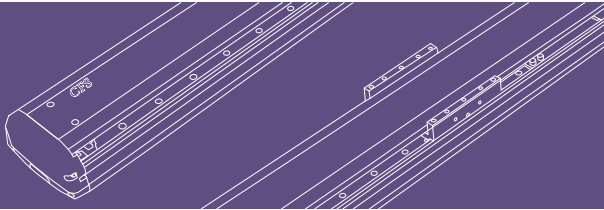

免費服務專線：大陸 400-716-8787
Toll-free Number China

基本仕様 Specification

規格 Spec	位置重複精度 Repeatability (mm)	±0.01			
	螺桿導程 Ball Screw Lead (mm)	10	20	32	
	最高速度 Maximum Speed (mm/s)	333	666	1066	
	最大可搬重量 Maximum Payload	水平使用 Horizontal (kg)	320	180	75
		垂直使用 Vertical (kg)	150	75	35
	定格推力 Rated Thrust (N)	3820	1910	1195	
標準行程 Stroke Pitch (mm)	50-1950mm/50間隔 50 mm Pitch				
部品 Parts	AC伺服馬達容量 AC Servo Motor Output (W)	1500			
	滾珠螺桿外徑 Ball Screw Ø (mm)	C7 φ 32			
	高剛性直線滑軌 High Rigidity Linear Guide (mm)	25			
	連軸器 Coupling (mm)	20X24/22(註1)			
	原點感應器 Home Sensor	外掛 Outside	EE-SX672(NPN)/FC-SPX303Z-2M(NPN)		
		內置 Built-In	EE-SX674(NPN)/FC-SPX307Z-2M(NPN)		

感應器接線圖<原點及端點> Sensor Layout

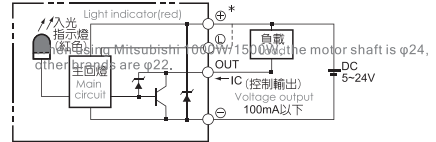

*行程超過1200時，會產生螺桿偏擺，此時請將速度調降。
*When the stroke is over 1200mm, the run-out of the ballscrew will occur. We recommend to low down the working speed under this circumstances.

*馬達最高轉速：2000 rpm。
*Maximum motor speed: 2000rpm.

*馬達加減速設定0.2秒。
*Acceleration and deceleration value is set 0.2 second.

註1：使用三菱1500W時，馬達軸心為φ24，其它品牌為φ22。
When using Mitsubishi/1500W, the motor shaft is φ24, other brands are φ22.

容許負載力距表 Allowable Overhang

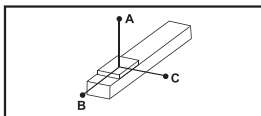

(單位 Unit : mm)

水平安裝 Horizontal Installation	A	B	C
導程 10 Lead	120	900	580
	160	860	390
	320	800	255
導程 20 Lead	100	1100	500
	140	1100	400
	180	1000	250
導程 32 Lead	60	650	560
	75	550	330

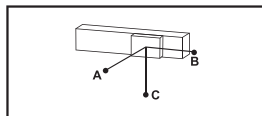

(單位 Unit : mm)

壁掛安裝 Wall Installation	A	B	C
導程 10 Lead	100	610	570
	150	390	386
	200	265	285
導程 20 Lead	80	600	600
	120	390	400
	160	260	300
導程 32 Lead	60	480	500
	70	300	320

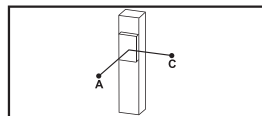

(單位 Unit : mm)

垂直安裝 Vertical Installation	A	C
導程 10 Lead	60	950
	90	720
	150	430
導程 20 Lead	40	1000
	60	830
	75	610
導程 32 Lead	35	650

靜態容許負載慣量 Static Loading Moment

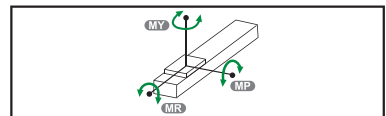

(單位 Unit : N.m)

MY	4408
MP	4408
MR	3860

*力距表所表示的數據，代表重心。
The torque value in the chart indicate the center of gravity.
*符合型錄規範的正常使用下，保證壽命為10000公里。
Operation life is 10,000km when the product is using under the specified conditions.
*倒吊使用無法套用標準規範，如有需求請洽詢我司業務。
Data information is not for ceiling-mount inverse use. Contact us for the details if you want to apply ceiling-mount inverse usage.

搭配伺服馬達一覽表 Suitable Motor Brand

廠牌 Brand	馬達記號 Mark	煞車有無 Brake	馬達容量 Watt	電源電壓 AC-Voltage	伺服馬達型號 Motor Model	驅動器型號 Driver Model
三菱 Mitsubishi	M	無煞車(水平仕様) No Brake (Horizontal Type)	1500	220	HG-SN152J-S100	MR-JE-200A
		有煞車(垂直仕様) With Brake (Vertical Type)	1500	220	HG-SN152BJ-S100	
松下 Panasonic	P	無煞車(水平仕様) No Brake (Horizontal Type)	1500	220	MDMF152L1G6	MDDL55SE
		有煞車(垂直仕様) With Brake (Vertical Type)	1500	220	MDMF152L1H6	
台達 Delta	T	無煞車(水平仕様) No Brake (Horizontal Type)	1500	220	ECM-B3M-E21315RS1	ASD-B3-1521-L
		有煞車(垂直仕様) With Brake (Vertical Type)	1500	220	ECM-B3M-E21315SS1	

應用例

一般/內嵌式樣

無塵/皮帶式樣

一般/螺桿式樣

齒輪齒條式樣

一般/螺桿式樣

一般/皮帶式樣

一般/皮帶式樣

無塵/螺桿式樣

無塵/皮帶式樣

直交連結

參考資料

單軸
1 axis
CFS

CFS5M

CFS6M

CFS10

CFS12

CFS13

CFS14

CFS17

CFS22

CFS27

CFS17M

CFS22M

CFS27 單軸/1-axis

▶ 長行程
Long Stroke

▶ 螺桿驅動
Ball Screw Drive

馬達外露/馬達下折

Motor Exposed / Motor Bottom Side

單位 Unit: mm

BC 馬達外露 Motor Exposed



• CAD圖面可至 www.cf16.com 下載 •

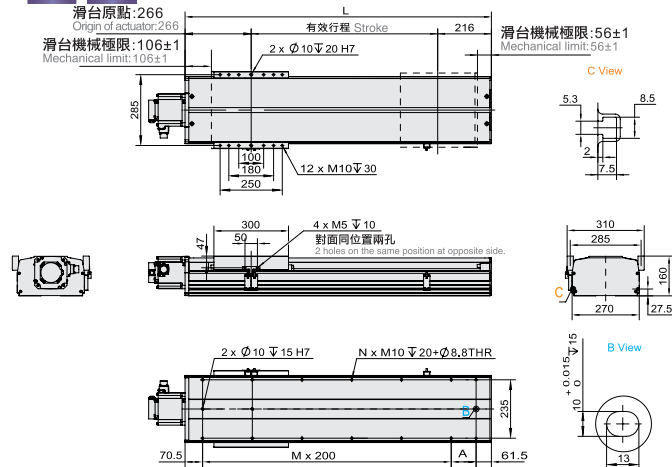

有效行程 stroke	50	100	150	200	250	300	350	400	450	500	550	600	650	700	750	800	850	900	950	1000
L	532	582	632	682	732	782	832	882	932	982	1032	1082	1132	1182	1232	1282	1332	1382	1432	1482
M	1	2	2	2	2	3	3	3	3	4	4	4	4	5	5	5	6	6	6	6
N	6	8	8	8	8	10	10	10	10	12	12	12	12	14	14	14	16	16	16	16
A	200	50	100	150	200	50	100	150	200	50	100	150	200	50	100	150	200	50	100	150
KG	43.20	44.07	44.94	45.81	46.68	47.55	48.42	48.42	50.16	51.03	51.90	52.77	53.64	54.51	55.38	56.25	57.12	57.99	58.86	59.73

有效行程 stroke	1050	1100	1150	1200	1250	1300	1350	1400	1450	1500	1550	1600	1650	1700	1750	1800	1850	1900	1950
L	1532	1582	1632	1682	1732	1782	1832	1882	1932	1982	2032	2082	2132	2182	2232	2282	2332	2382	2432
M	6	7	7	7	7	8	8	8	8	9	9	9	9	10	10	10	11	11	11
N	16	18	18	18	18	20	20	20	20	22	22	22	22	24	24	24	26	26	26
A	200	50	100	150	200	50	100	150	200	50	100	150	200	50	100	150	200	50	100
KG	60.60	61.47	62.34	63.21	64.08	64.95	65.82	66.69	67.56	68.43	69.30	70.17	71.04	71.91	72.78	73.65	74.52	75.39	76.26

BM 馬達下折 Motor Bottom Side



• CAD圖面可至 www.cf16.com 下載 •

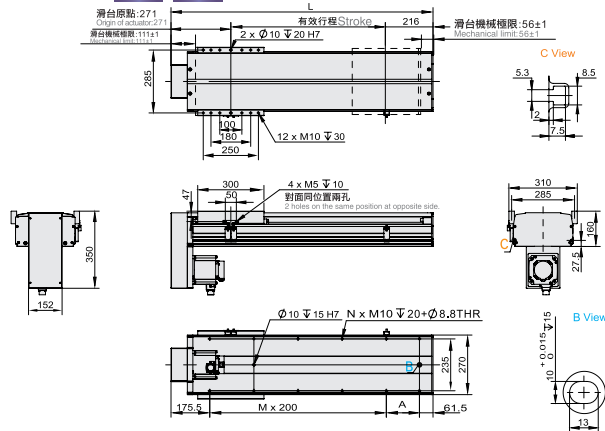

有效行程 stroke	50	100	150	200	250	300	350	400	450	500	550	600	650	700	750	800	850	900	950	1000
L	537	587	637	687	737	787	837	887	937	987	1037	1087	1137	1187	1237	1287	1337	1387	1437	1487
M	1	1	1	2	2	2	2	3	3	3	3	4	4	4	4	5	5	5	5	6
N	6	6	6	8	8	8	8	10	10	10	10	12	12	12	12	14	14	14	14	16
A	100	150	200	50	100	150	200	50	100	150	200	50	100	150	200	50	100	150	200	50
KG	45.26	46.13	47.00	47.87	48.74	49.61	50.48	51.35	52.22	53.09	53.96	54.83	55.70	56.57	57.44	58.31	59.18	60.05	60.92	61.79

有效行程 stroke	1050	1100	1150	1200	1250	1300	1350	1400	1450	1500	1550	1600	1650	1700	1750	1800	1850	1900	1950
L	1537	1587	1637	1687	1737	1787	1837	1887	1937	1987	2037	2087	2137	2187	2237	2287	2337	2387	2437
M	6	6	6	7	7	7	7	8	8	8	8	9	9	9	9	10	10	10	10
N	16	16	16	18	18	18	18	20	20	20	20	22	22	22	22	24	24	24	24
A	100	150	200	50	100	150	200	50	100	150	200	50	100	150	200	50	100	150	200
KG	62.66	63.53	64.40	65.27	66.14	67.01	67.88	68.75	69.62	70.49	71.36	72.23	73.10	73.97	74.84	75.71	76.58	77.45	78.32

免費服務專線：大陸 400-716-8787
Toll-free Number China

馬達左折/馬達右折

Motor Left Side / Motor Right Side

單位 Unit : mm

BL 馬達左折 Motor Left Side   [CAD圖面可至 www.cf16.com 下載](http://www.cf16.com)

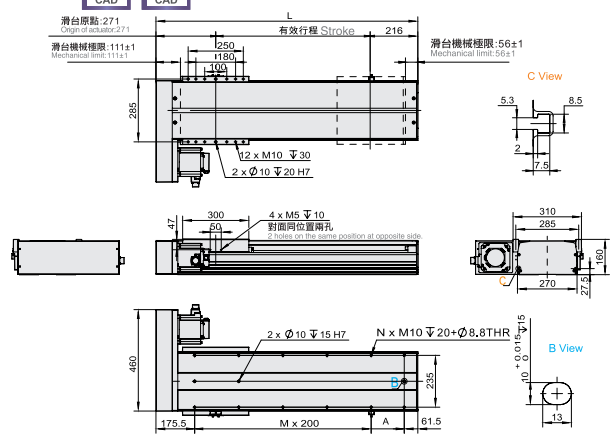

有效行程 stroke	50	100	150	200	250	300	350	400	450	500	550	600	650	700	750	800	850	900	950	1000
L	537	587	637	687	737	787	837	887	937	987	1037	1087	1137	1187	1237	1287	1337	1387	1437	1487
M	1	1	1	2	2	2	2	3	3	3	3	4	4	4	4	5	5	5	5	6
N	6	6	6	8	8	8	8	10	10	10	10	12	12	12	12	14	14	14	14	16
A	100	150	200	50	100	150	200	50	100	150	200	50	100	150	200	50	100	150	200	50
KG	45.26	46.13	47.00	47.87	48.74	49.61	50.48	51.35	52.22	53.09	53.96	54.83	55.70	56.57	57.44	59.31	59.18	60.05	60.92	61.79

有效行程 stroke	1050	1100	1150	1200	1250	1300	1350	1400	1450	1500	1550	1600	1650	1700	1750	1800	1850	1900	1950
L	1537	1587	1637	1687	1737	1787	1837	1887	1937	1987	2037	2087	2137	2187	2237	2287	2337	2387	2437
M	6	6	6	7	7	7	7	8	8	8	8	9	9	9	9	10	10	10	10
N	16	16	16	18	18	18	18	20	20	20	20	22	22	22	22	24	24	24	24
A	100	150	200	50	100	150	200	50	100	150	200	50	100	150	200	50	100	150	200
KG	62.66	63.53	64.40	65.27	66.14	67.01	67.88	68.75	69.62	70.49	71.36	72.23	73.10	73.97	74.84	75.71	76.58	77.45	78.32

BR 馬達右折 Motor Right Side   [CAD圖面可至 www.cf16.com 下載](http://www.cf16.com)

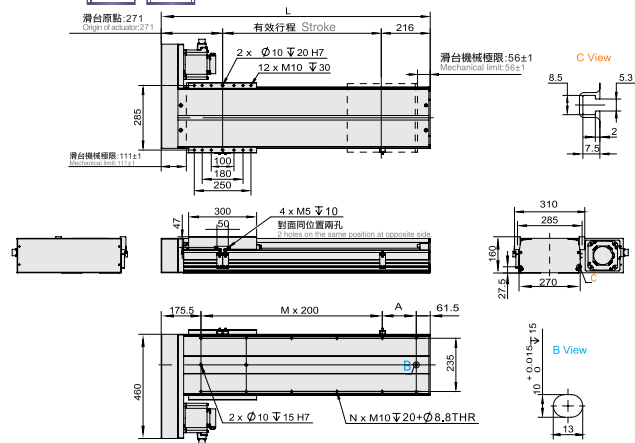

有效行程 stroke	50	100	150	200	250	300	350	400	450	500	550	600	650	700	750	800	850	900	950	1000
L	537	587	637	687	737	787	837	887	937	987	1037	1087	1137	1187	1237	1287	1337	1387	1437	1487
M	1	1	1	2	2	2	2	3	3	3	3	4	4	4	4	5	5	5	5	6
N	6	6	6	8	8	8	8	10	10	10	10	12	12	12	12	14	14	14	14	16
A	100	150	200	50	100	150	200	50	100	150	200	50	100	150	200	50	100	150	200	50
KG	45.26	46.13	47.00	47.87	48.74	49.61	50.48	51.35	52.22	53.09	53.96	54.83	55.70	56.57	57.44	59.31	59.18	60.05	60.92	61.79

有效行程 stroke	1050	1100	1150	1200	1250	1300	1350	1400	1450	1500	1550	1600	1650	1700	1750	1800	1850	1900	1950
L	1537	1587	1637	1687	1737	1787	1837	1887	1937	1987	2037	2087	2137	2187	2237	2287	2337	2387	2437
M	6	6	6	7	7	7	7	8	8	8	8	9	9	9	9	10	10	10	10
N	16	16	16	18	18	18	18	20	20	20	20	22	22	22	22	24	24	24	24
A	100	150	200	50	100	150	200	50	100	150	200	50	100	150	200	50	100	150	200
KG	62.66	63.53	64.40	65.27	66.14	67.01	67.88	68.75	69.62	70.49	71.36	72.23	73.10	73.97	74.84	75.71	76.58	77.45	78.32